

SIDE VIEW

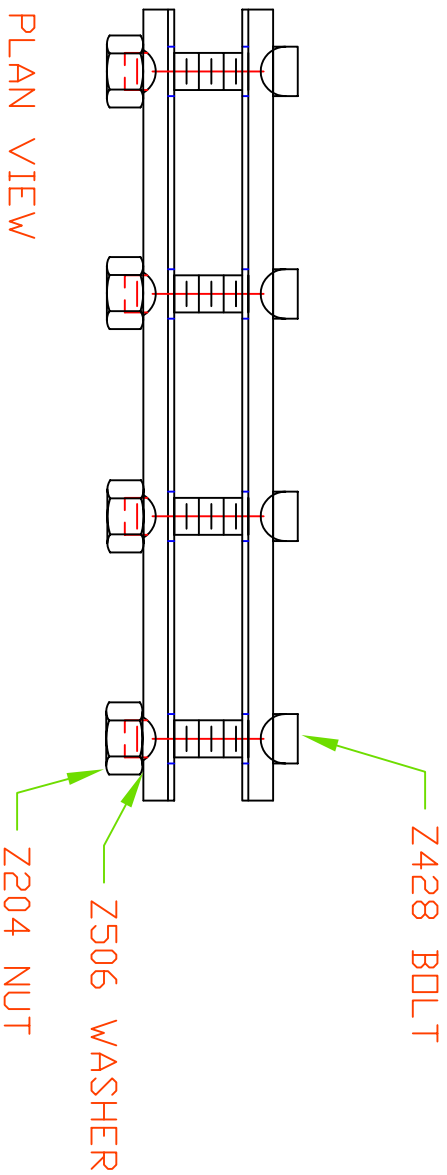

PLAN VIEW

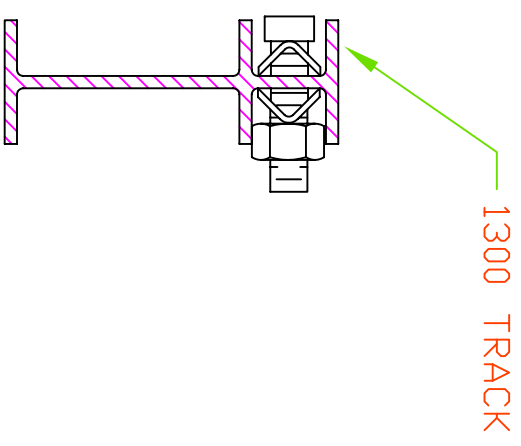

SECTION

INSTRUCTIONS FOR PROPER SPACING:

1. BUTT TRACK SECTIONS AGAINST EACH OTHER.
2. CENTER ONE HALF OF THE SPLICE CLAMP OVER THE JOINT.
3. MARK LOCATION OF THE CLAMP HOLES ON THE TRACK.
4. DRILL (4) 3/16" DIA. HOLES FOR BOLTS.
5. PLACE BOTH SPLICE CLAMP HALVES OVER JOINT AND SECURE WITH HARDWARE PROVIDED. BE SURE TO TIGHTEN SECURELY.

AUTOMATIC DEVICES COMPANY
 2121 S. 12TH ST. ALLENTOWN, PA 18103

THIS DRAWING HAS BEEN PREPARED AS A SERVICE TO OUR CUSTOMER AND IS INTENDED ONLY TO BE SUGGESTIVE IN NATURE AND IS NOT TO BE USED AS AN ACTUAL INSTALLATION DRAWING. PREVAILING JOB CONDITIONS AND ACCEPTED PRACTICES MUST BE TAKEN INTO ACCOUNT WHEN THE EQUIPMENT IS INSTALLED.

SIZE	DATE	FORM	REV
A	05/27/10	408	
DRAWN BY DJL		APPROVED BY	
DESCRIPTION 1324 SPLICING CLAMP			
SCALE 1" = 1"	SHEET 1 OF 1	DWG NO. A-1324-10	