

TOP VIEW

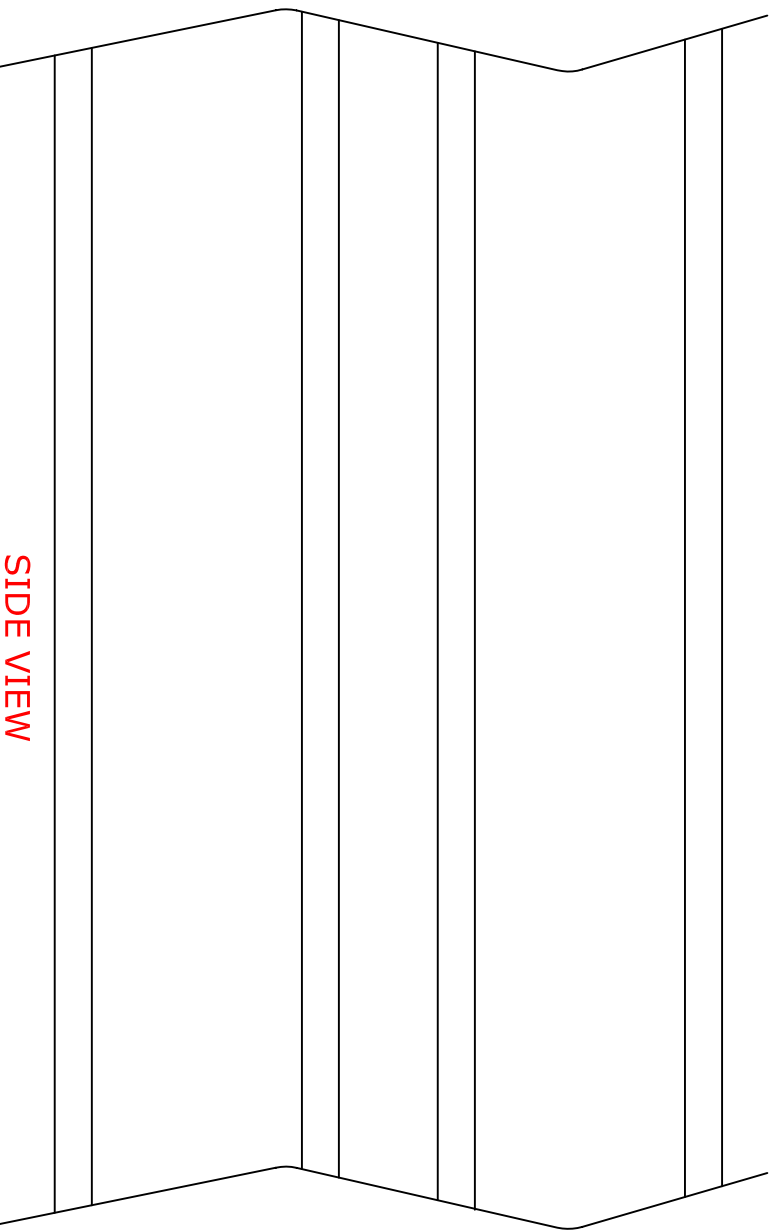

SIDE VIEW

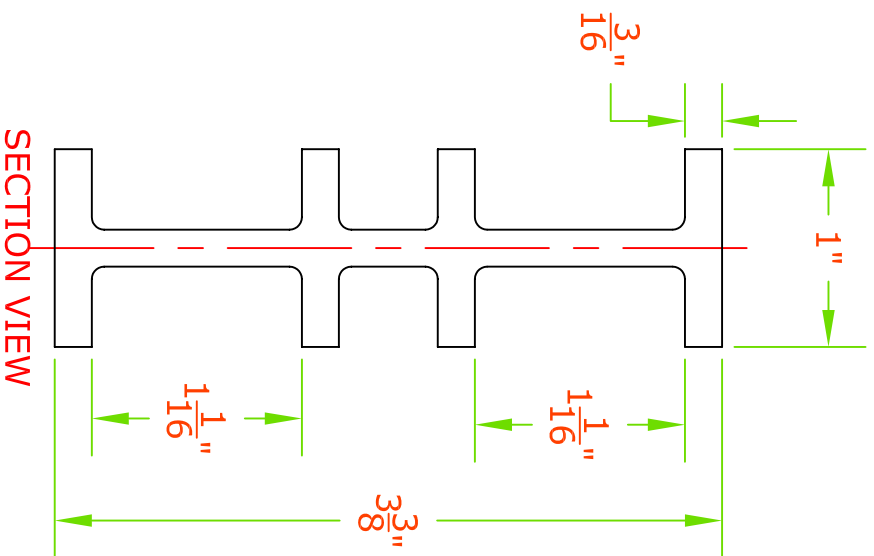

SECTION VIEW

MILL FINISH ALUMINUM

MAXIMUM SECTION LENGTH - 20'

SOLD IN EVEN FOOTAGES ONLY

THIS DRAWING HAS BEEN PREPARED AS A SERVICE TO OUR CUSTOMER AND IS INTENDED ONLY TO BE SUGGESTIVE IN NATURE AND IS NOT TO BE USED AS AN ACTUAL INSTALLATION DRAWING. PREVAILING JOB CONDITIONS AND ACCEPTED PRACTICES MUST BE TAKEN INTO ACCOUNT WHEN THE EQUIPMENT IS INSTALLED.

AUTOMATIC DEVICES COMPANY
2121 S. 12TH ST. ALLENTOWN, PA 18103

SIZE	DATE	MODEL	DESCRIPTION	REV
A	09/09/10	420	TRIPPL-I-TRAC	

DRAWN BY	APPROVED BY	DESCRIPTION
DJL		4200 TRACK

SCALE	SHEET	OF	DWG NO.
1" = 1"	1	1	A-4200-10

SCALE	SHEET	OF	DWG NO.
1" = 1"	1	1	A-4200-10